

Density Error and its Correction in Boiler Drum Level Indication

Presented at the International Society for Measurement and Control (ISA) Conference, October, 1995

ABSTRACT

The requirements for power boiler level indication are clearly stated in the ASME Boiler and Pressure Code Section I, Paragraph 60.1.1. In addition to the direct reading gage glass, remote liquid level indicators of various types are permitted under certain design conditions.

Regardless of the instrument selected, consideration must be given to the level error caused by connecting an external device to the boiler drum. The error is inherent because the level measuring instrument is at a lower temperature than the boiler.

Various mechanical and electronic solutions are available to minimize the level indication error. The purpose of this evaluation was to determine the actual level error under various laboratory conditions for three types of water level gages and for an electronic level gage column. Lab measurements were compared with both design theory and field observations. All this information was then used together to improve product design, application and installation procedures that would minimize boiler level indication error.

INTRODUCTION

Boiler steam drum water level is one of the most important power plant parameters to measure and control. If the level is too low, boiler tubes will be damaged by overheating. If the level is too high, the superheater tubes and the turbine may be damaged by moisture or water treatment chemical carryover. As boiler operating pressures and boiler drum wall thickness have increased, many boilers have become smaller. This reduced boiler drum volume demands even more accurate level control.

A variety of instruments are available and approved by the ASME for power boiler level indication. However, simply specifying one or more of these instruments will not guarantee that the boiler level will be indicated accurately. The user must thoroughly understand the operating principles of each instrument, instrument installation requirements and the boiler operating scheme.

A difference in the water density between the level instrument and the boiler is the major source of level error. The purpose of this evaluation was to

determine the actual level error of several instruments under various controlled laboratory conditions. These measurements would then be compared with both design theory and field observations to develop installation requirements and an understanding of specific application limitations.

LEVEL INDICATION REQUIREMENTS

The requirements for boiler level indication are clearly stated in the ASME Boiler and Pressure Vessel Code, Section I, Paragraph 60.1.1. A combination of gage glasses and remote level indicators are required as follows:

Each boiler (except forced flow steam generators with no fixed steam and waterline, and high temperature water boilers of the forced circulation type that have no steam and waterline) shall have at least one water gage glass. (Figure 1a).

Boilers operated at pressures over 400 psi (except electric boilers of the electrode type) shall have two water gage glasses (Figure 1b).

Boilers with safety valves set at or above 400 psi may operate two independent remote level indicators

instead of one of the two required gage glasses (Figure 1c). When both remote level indicators are in reliable operation, the remaining gage glass may be shut off, but shall be maintained in serviceable condition. (Code Case 2109)

REMOTE LEVEL INDICATORS

Several devices have been developed over the years to take advantage of the option offered by the Boiler Code for two independent remote level indicators instead of one of the two required gage glasses. These devices include:

1. *Differential Pressure Indicator.* These are available in both the mechanical and electronic type (Figure 2). Both measure the differential pressure between a reference water level and the boiler level.
2. *Electronic Water Level Gage* (Figure 3). This device measures water level through conductivity probes installed in a water column connected to the boiler.

ASME BOILER AND PRESSURE VESSEL CODE REQUIREMENTS

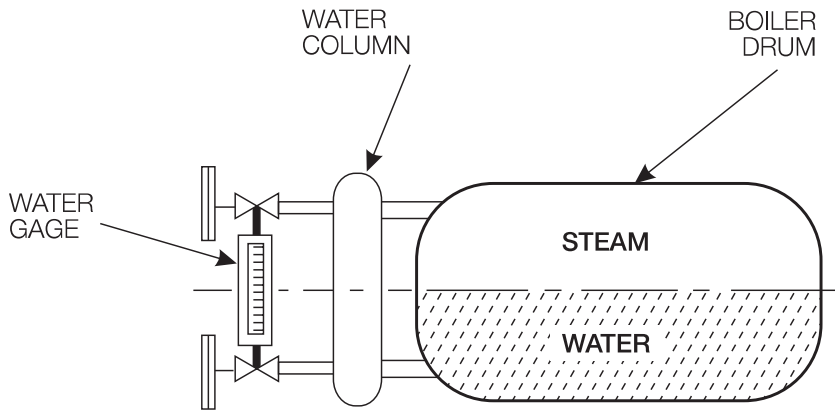

(a) Boiler pressure less than 400 psi

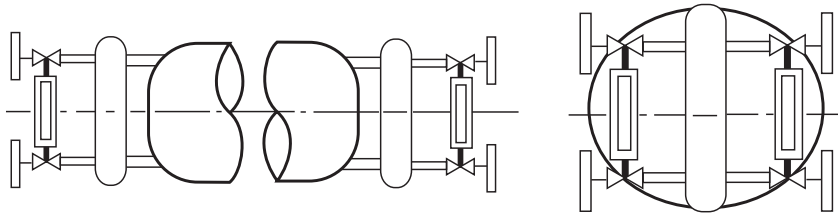

(b) Boiler pressure greater than 400 psi

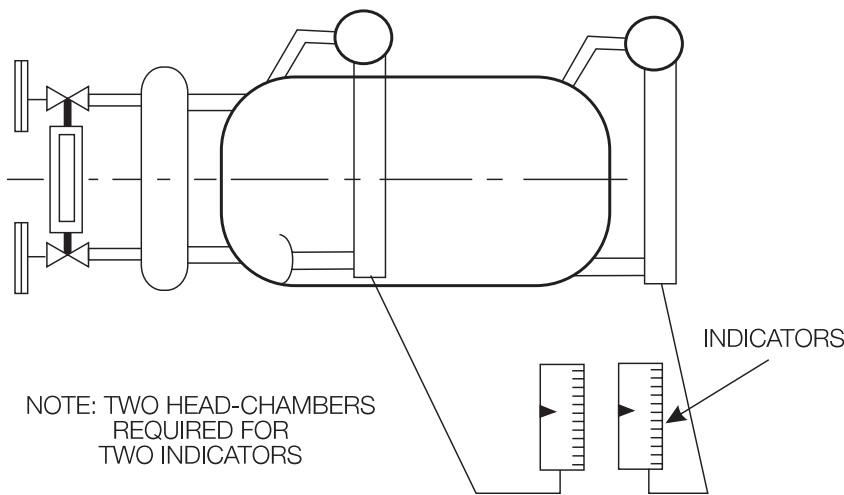

(c) Boiler pressure greater than 400 psi with remote indicators

Figure 1

DENSITY LEVEL ERROR

Water level gages and all types of remote level indicators are affected by density level error. This level measurement error occurs because the water measured by the device is colder than the boiler water, creating a density difference. This system can be explained and modeled by a U Tube Manometer (Figure 4).

The manometer contains fluid with three different densities. On one side is saturated water with boiler water density D_d . On the other side are two fluids: water in the gage with an unknown density D_g , and saturated Steam with density D_s .

A pressure balance at point "A" in this system produces the following relationships:

Equation 1.

$$H_d D_d = H_g D_g + H_s D_s$$

Equation 2.

$$H_s = H_d - H_g$$

Equation 3.

$$H_g = \frac{H_d (D_d - D_s)}{D_g - D_s}$$

Equation 4.

$$H_d = \frac{H_g (D_g - D_s)}{D_d - D_s}$$

The use of these formulas to determine the actual drum water level, H_d , can be explained with the following example.

Example:

Boiler operating pressure 3000 psia.

Average gage temperature is 20°F below saturated steam temperature.

H_g , water level in the gage is 20 inches above the water connection.

Using the steam tables:

$$D_s = 11.90 \text{ lbm/ft}^3$$

$$D_d = 31.94 \text{ lbm/ft}^3 \text{ (Assume the average water temperature in the drum is } 10^\circ\text{F below saturation)}$$

$$D_g = 33.89 \text{ lbm/ft}^3$$

$$H_d = 20 \text{ inches} \frac{(33.89 - 11.90)}{31.94 - 11.90}$$

$$H_d = 22.0 \text{ inches, or a 10\% error.}$$

The factors that determine the magnitude of the level error are the operating

REMOTE LEVEL INDICATOR—DIFFERENTIAL PRESSURE

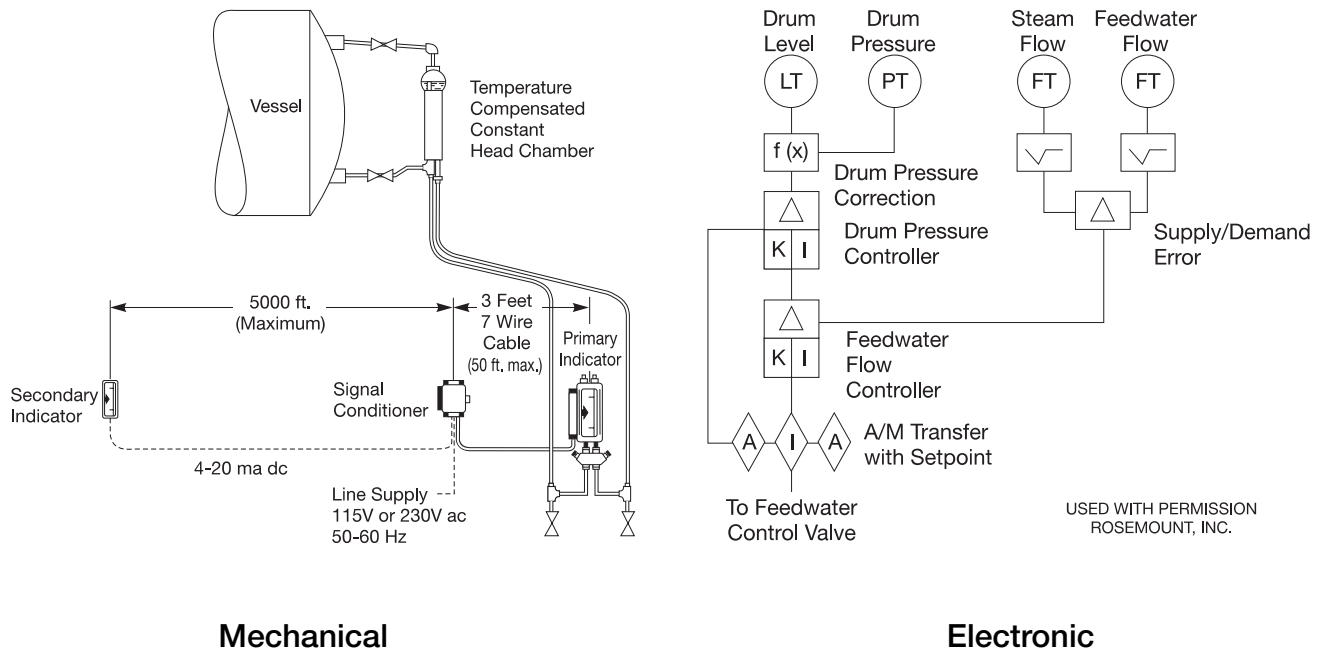

Figure 2

ELECTRONIC WATER LEVEL GAGE

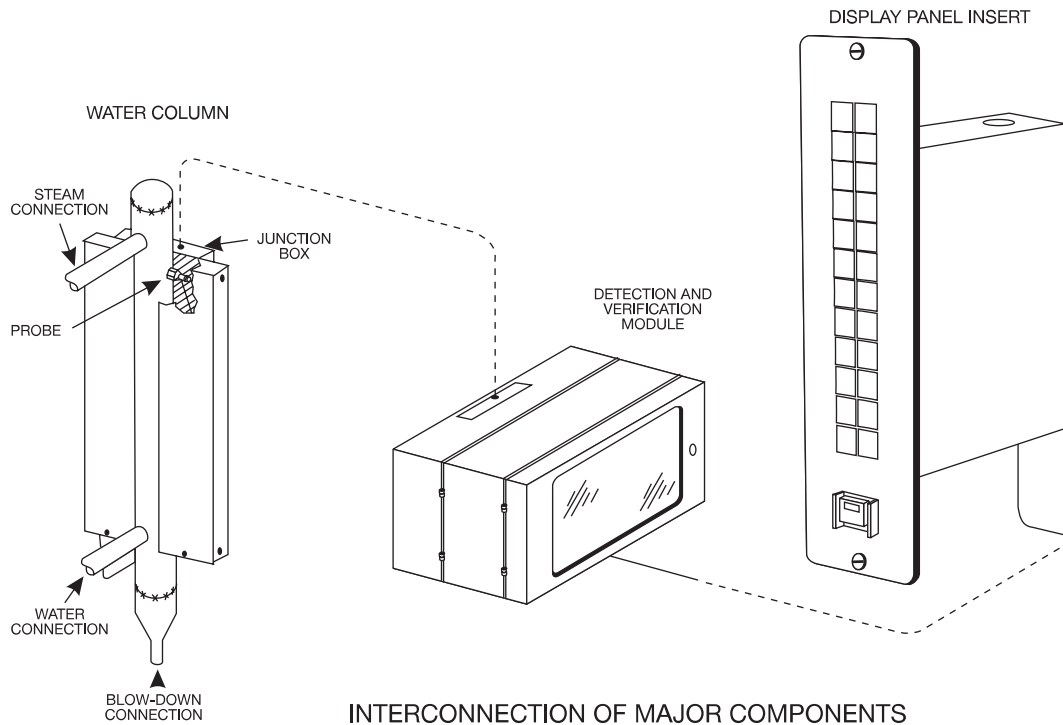

Figure 3

LEVEL GAGE AND "U" TUBE EQUIVALENT

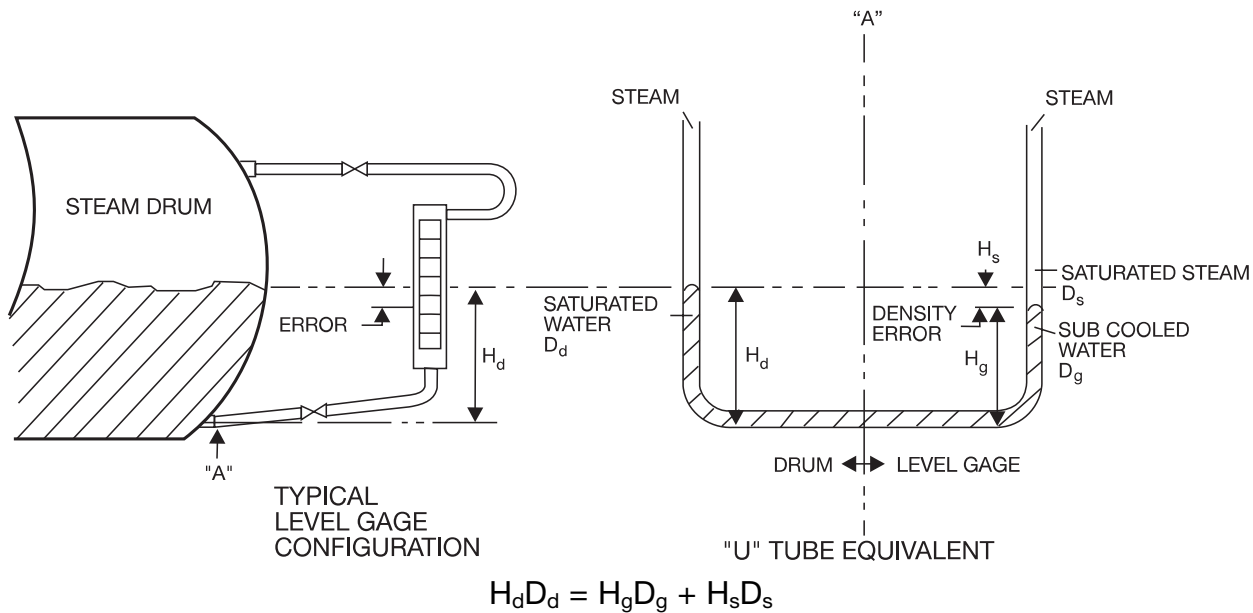

Figure 4

GAGE OPERATING PRESSURE AND SUBCOOLING EFFECT ON LEVEL ERROR

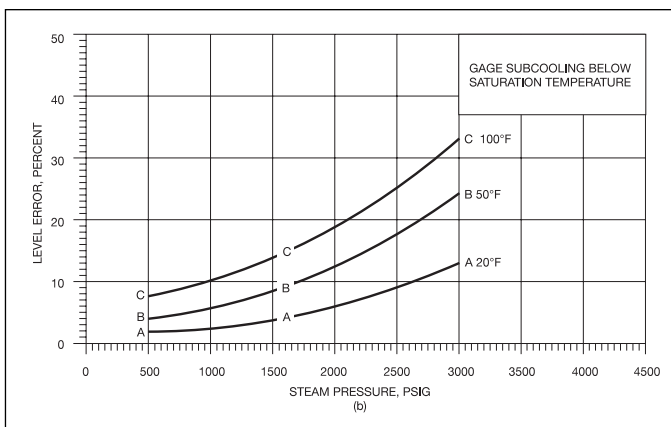
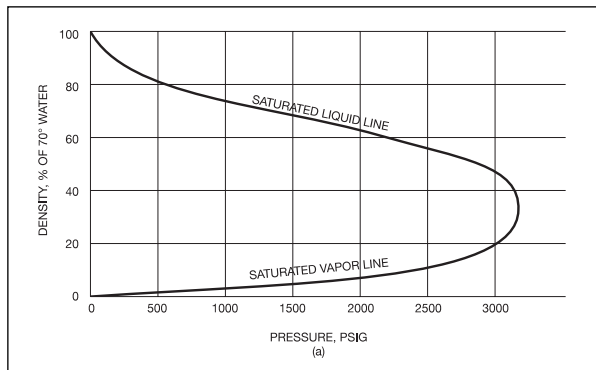

Figure 5

pressure, the gage subcooling, and the boiler drum level above the gage return connection. Figure 5 shows the effect of operating pressure and gage subcooling on gage error. As pressure increases, the density of saturated liquid and saturated steam converge (Figure 5a). As gage subcooling increases, the level error increases (Figure 5b). As the drum level H_d increases, the level error increases proportionally. H_d can be minimized by returning the water pipe from the gage horizontally to the drum, and by designing the drum water connection to be a minimum distance below the lowest gage view port.

However, a significant question remains unanswered. What is the average gage temperature and corresponding density D_g ?

LEVEL GAGE DYNAMICS

Standard level gages and electronic level gages connected to the boiler are not in a static condition. If they were, the water temperature in the gage would be near ambient. Referring to Figure 6, steam condenses in the supply piping and upper gage to the gage waterline. This saturated water raises the gage water level slightly above the equilibrium point. The excess water flows back into the boiler drum. The circulation flow depends upon the condensing steam rate and the volume in the gage and water return piping.

The condensing steam enters the gage at the saturation temperature. The condensate continues to cool until it re-enters the boiler. A profile of this temperature gradient is shown in Figure 6.

Many level gages are connected to the boiler with a "tie bar" or "water column" because the visibility of the gage may be adversely affected by excessive water flowing over the glass. The tie bar short circuits the excess water from the steam supply piping. The only flow through the gage is from steam condensing in the gage itself and the gage piping.

Gages and remote level indication devices will indicate incorrectly if boiler pressure decreases suddenly. The temperature of the water in the gage or reference column is normally within a hundred degrees of the saturation temperature. If the boiler pressure should decrease rapidly, the water in the gage will flash to steam. The steam bubbles will cause the level in

LEVEL GAGE WATER FLOW DYNAMICS

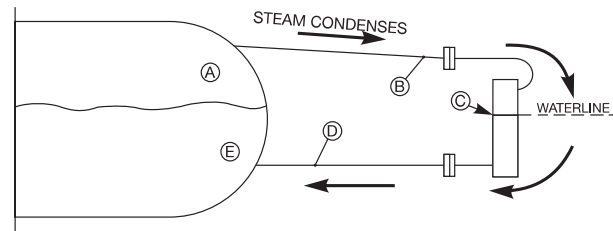

GAGE WATER TEMPERATURE PROFILE

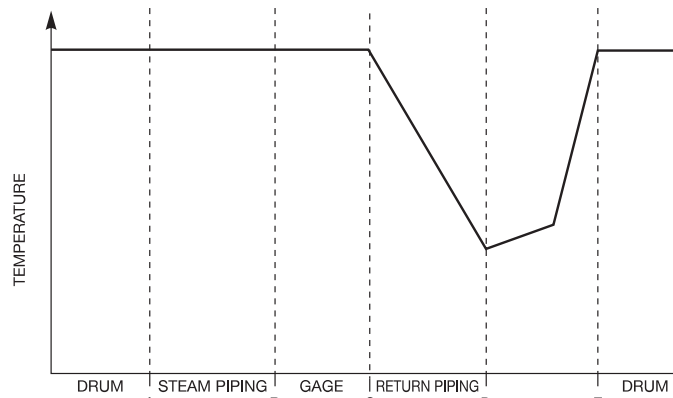

Figure 6

the glass to rise and will often obliterate the meniscus. Indication will return to normal when thermal equilibrium is re-established. Systems utilizing a reference column will indicate high as water in the reference leg flashes to steam. Indication will return to normal very slowly as steam condenses to refill the reference leg. The reference leg can also be manually filled to establish proper indication more quickly.

GAGE CORRECTION OPTIONS

Every level measurement device must be corrected in some manner to compensate for density level error. A number of techniques have evolved over the years to address each individual device.

1. *Differential Pressure Indicator, mechanical type* (Figure 2). The device is installed with a tempera-

ture compensated reference column. The purpose of this equipment is to heat the water in the reference leg to a value that is halfway between saturation and ambient. This corrects the indication if the level is at the mid scale position, regardless of pressure. An additional pressure sensing device is added to correct the pointer for water levels that are above or below the mid scale value.

2. *Differential Pressure Indicator, electronic type* (Figure 2). The most sophisticated of the devices measures the differential pressure of the reference and variable legs with both at ambient temperature. The ambient temperature and the boiler operating pressure are also measured. An analog or digital program then corrects the apparent differential for boiler water density to indicate the boiler level.

WATER LEVEL GAGE TEST SETUP

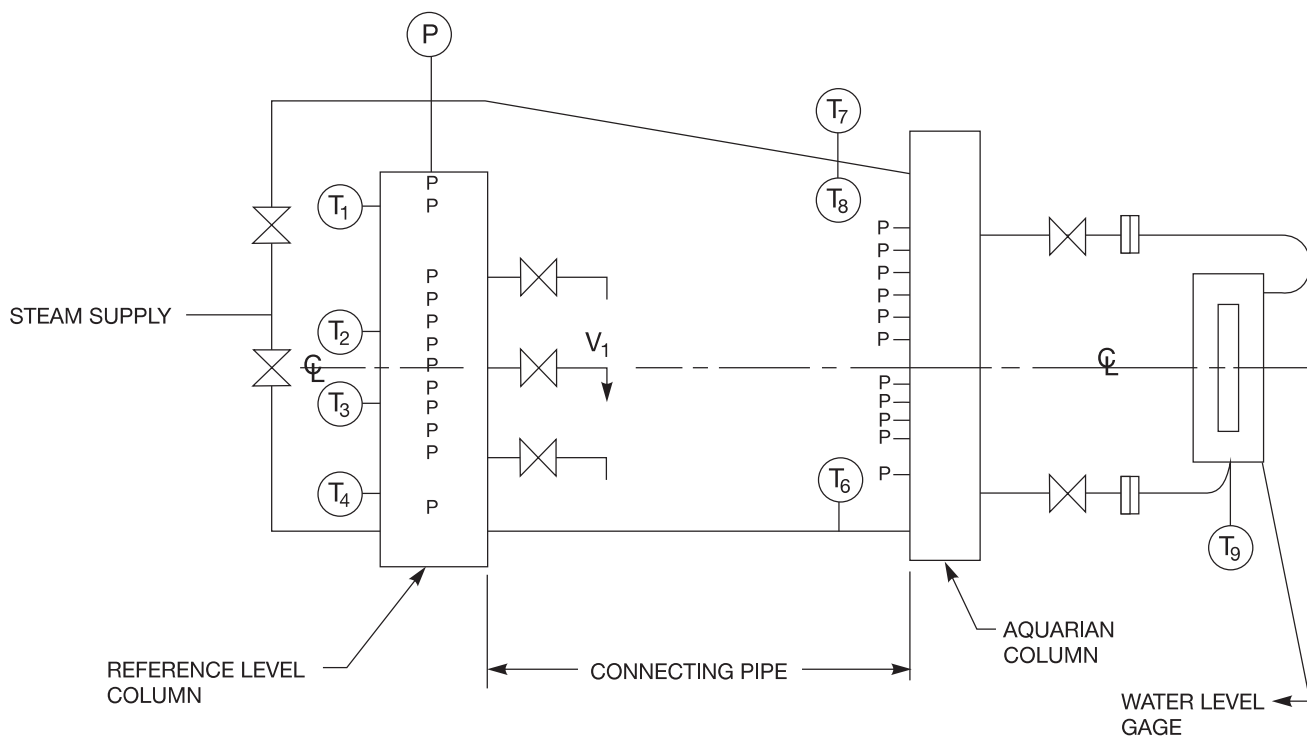

Figure 7

Less sophisticated devices are calibrated to read correctly at only one pressure, usually the normal operating pressure. They will indicate improperly when operated at pressures above or below the calibration pressure.

3. *Water Level Gages, direct reading and electronic type.* As discussed earlier, the primary difficulty in calculating the level error for devices of this type is to determine the average gage water temperature and corresponding water density. When this is calculated or measured, then the gage glass is physically installed in a lower position to compensate for this error. Steam heated level gages are available that significantly reduce the density error. But these may be especially susceptible to boiler pressure transients. The electronic gage can be corrected by locating each probe individually to correct for the error at that level.

DENSITY LEVEL ERROR TEST PROGRAM AND TEST RESULTS

A test apparatus was constructed in the Yarway Test Lab, shown in Figure 7, to measure the level error and gage temperature of various gages under a variety of conditions. Probes of the same type used in the electronic gage were installed with 1/2" spacing in a reference level column. The water in the reference column was maintained within 10°F of saturation temperature. The level was maintained at a known point by throttling control valve V₁. The gage under test was connected to the reference column with typical piping and valves.

Tests on various devices were performed with a variety of connecting pipe sizes, pipe lengths, operating pressures and insulation conditions. Since most of this information is proprietary in nature, only general characteristics will be discussed.

Figure 8 shows the level error and temperature gradient for a typical gage as a function of operating pressure. As expected, the level error increases with operating pressure. However, the temperature difference between saturation and the water outlet remained relatively constant. This is because the steam condensing rate increases significantly as pressure increases. Performance graphs were developed for each gage and configuration evaluated. Performance changes related to installation are summarized in Table I.

Figure 8 shows the effect of connecting a standard level gage to an electronic level gage in two different manners. In the first case the gage lower connection is attached 4" above the water return connection. In the second case it is attached at the same height as the water return connection. Connection in the second manner causes minimal change to the normal temperature profile of the electronic water gage.

TYPICAL GAGE LEVEL ERROR AND AVERAGE TEMPERATURE

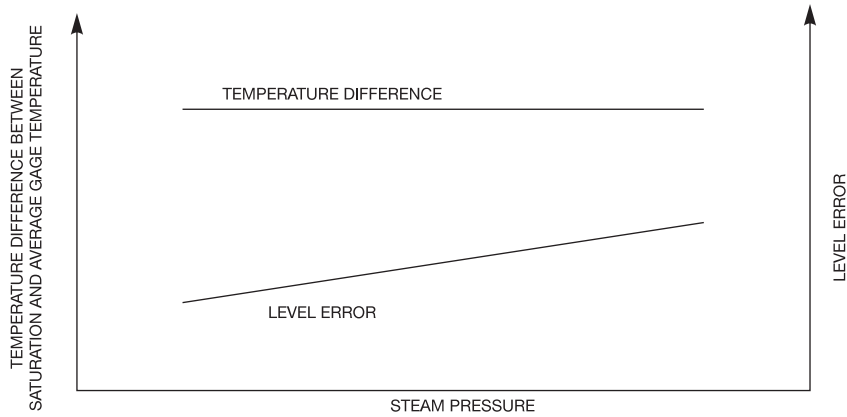

GAGE CONNECTION EFFECT ON ELECTRONIC LEVEL GAGE PERFORMANCE

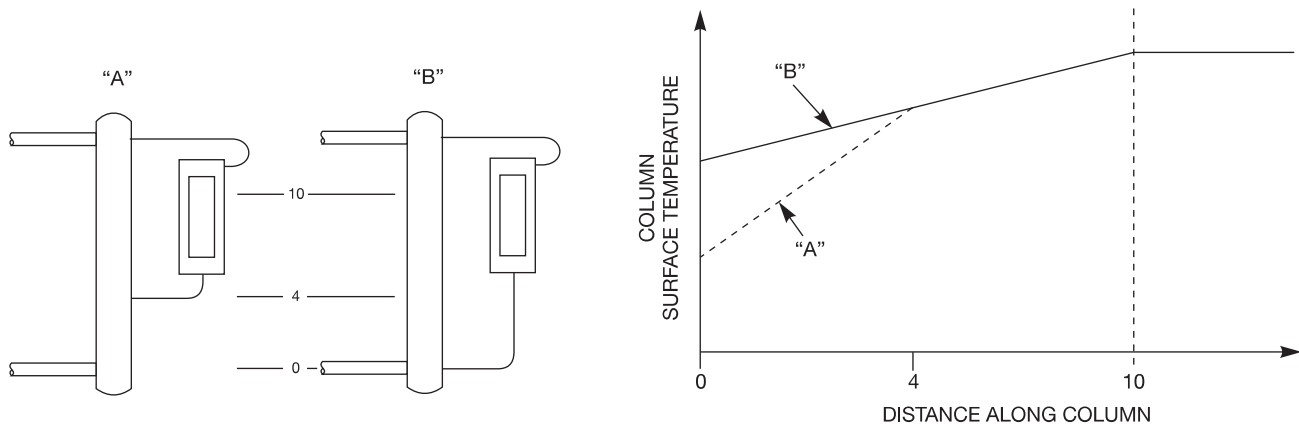

Figure 8

TABLE I

Configuration	Gage Temperature	Level Error
Gage Insulated	Increases	Decreases
* Steam supply pipe diameter larger	Increases	Decreases
* Steam supply pipe length longer	Increases	Decreases
Gage water level lower	Increases	Decreases

* Only applies to the electronic gage column since all standard gages were tested with a "tie bar" installed.

CONCLUSIONS

The water level gage glass has been used for many years to indicate boiler water level and it is required by the ASME Boiler and Pressure Vessel Code. A number of supplementary indicators are available that provide convenient remote indication and level control. All of these devices are subject to indication error because the water measured is external to the drum and is not at the same density as the boiler drum water.

A number of techniques have been developed for each indicating device to address this problem. The electronic dp indicator can be adjusted by an analog or digital program. The mechanical dp indicator uses a temperature compensated reference chamber with a pressure compensation device. The standard level gage and the electronic level gage can be corrected by measuring or calculating the average gage water temperature and installing the gage in the proper location.

Testing confirms that the gage temperature is affected by a large number of conditions: steam supply and return pipe size, length and configuration; insulation, ambient conditions and water level. Maintaining the gage water temperature very close to the saturation temperature will have an adverse effect on indication if the pressure drops suddenly. However, if the gage temperature is significantly less than the boiler water temperature, the level error will be significant at high pressure.

The best compromise is to determine the average gage temperature and the gage level error that will exist under certain boiler operating conditions. Then, the gage installation position can be corrected accordingly. For the electronic level gage, probes can be located individually to indicate properly. For the visual level gage, repositioning the unit can compensate for the density error. It is vital that the gage installation follow the manufacturer's specifications. Only then will the level device indicate accurately and perform as designed and tested.

REFERENCES

- Williams, James
"Methods of Obtaining Accurate Boiler Water Level Indication," ASME Power Division Winter Annual Meeting, New York, NY, December, 1960
- Spencer, J. D.
"Design Considerations for an Electronic Water Gage," Fossil Power Systems Technical Publication 1988.
- "Boiler Drum Level Indication in High Pressure Boilers," Yarway Technical Publication, November, 1992
- Spencer, J. D.
"Density Error Considerations for Steam Drum Water Gage Systems," Nova Scotia Power Corp., Nova Scotia, Canada, June 1991.
- "Boiler Drum Pressure Correction," Rosemount application data sheet 3084, August 1990.



www.tycoflowcontrol.com

